

en Installation instructions
de Hinweise zur Installation und zum Aufstellungsort
ro Instrucțiuni de instalare
fr Instructions d'installation
it Istruzioni di installazione
tr Montaj Talimatları

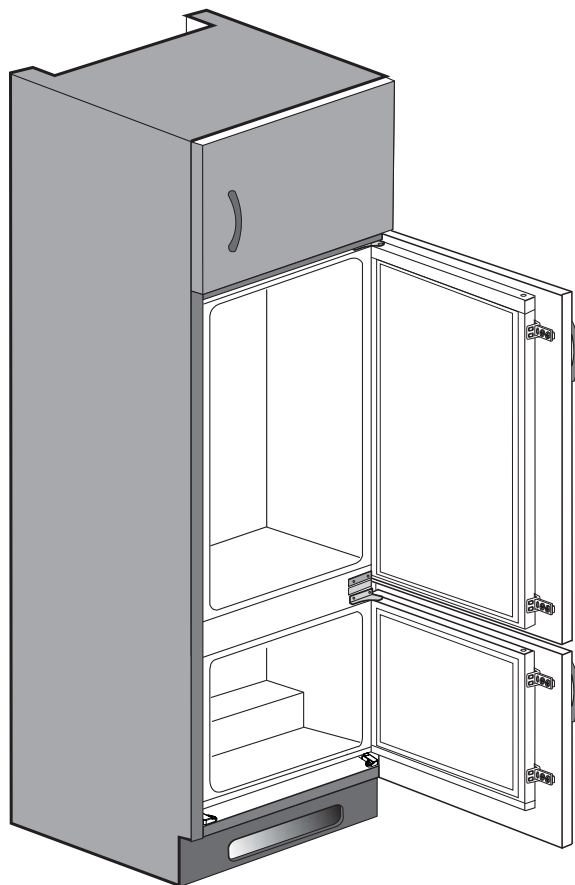

4578346310/AF

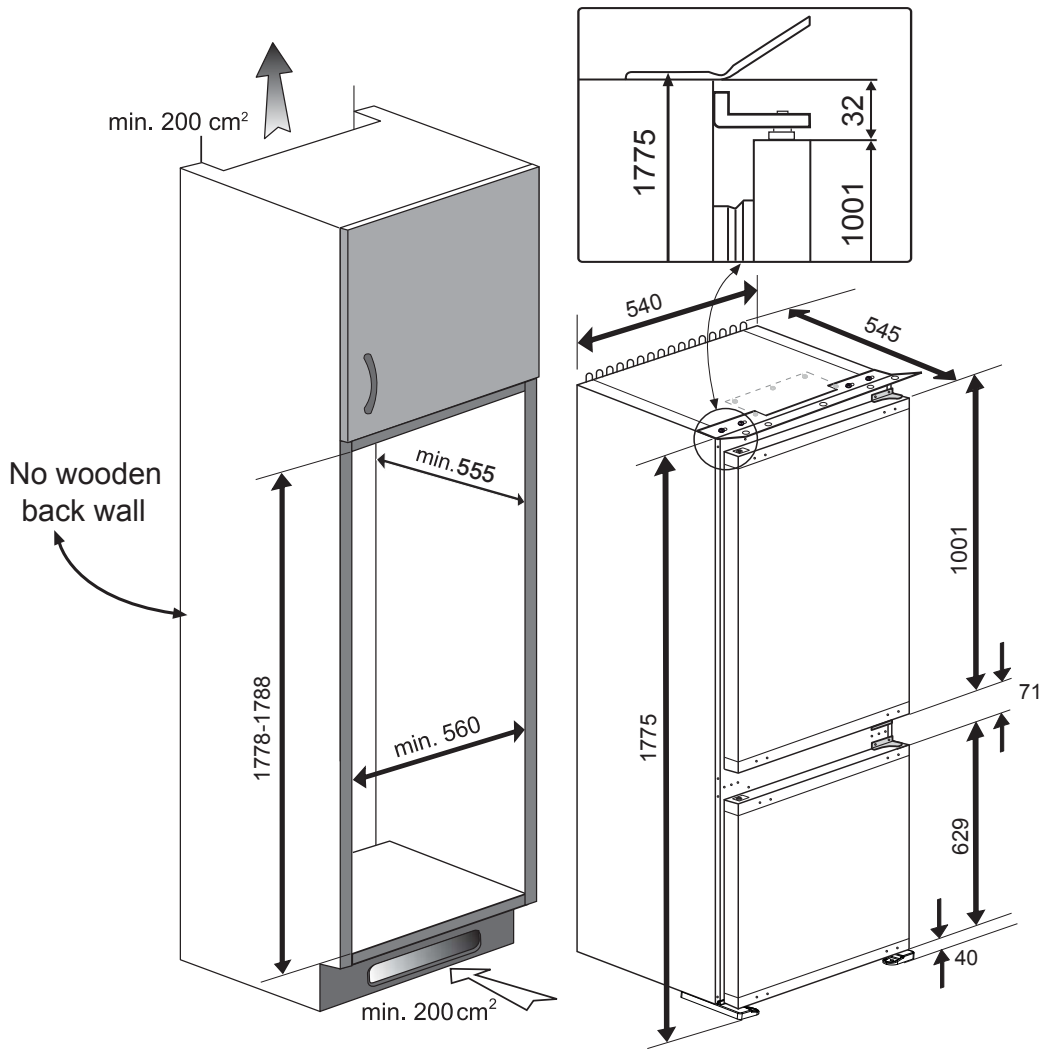

The back wall of the wooden cabinet must be left open completely to kitchen wall in order to allow sufficient air circulation to cool down the condenser unit for energy efficiency.

Die Rückseite des Holzschrankes muss zur Küchenwand hin vollständig offen bleiben, damit eine ausreichende Luftzirkulation für die Abkühlung des Kondensators zur Gewährleistung der Energieeffizienz sorgt.

Partea posterioară a dulapului, către peretele bucătăriei, trebuie să fie lăsată complet deschisă, pentru a permite o circulație de aer suficientă, care să răcească condensatorul, pentru a avea eficiență energetică.

La paroi arrière du meuble en bois doit être laissée complètement ouverte contre le mur de la cuisine, afin de permettre une circulation d'air suffisante pour refroidir le produit.

La parete posteriore dell'armadio in legno deve essere lasciata completamente aperta verso la parete della cucina per consentire una circolazione d'aria sufficiente a raffreddare il condensatore per garantire una sufficiente alimentazione.

Enerji tasarrufu için buzdolabı arkasında yeterli hava sirkülasyonu sağlanmalıdır. Bu amaçla buzdolabının içine yerleştirileceği ahşap kabinin arka yüzeyi kapatılmamalıdır.

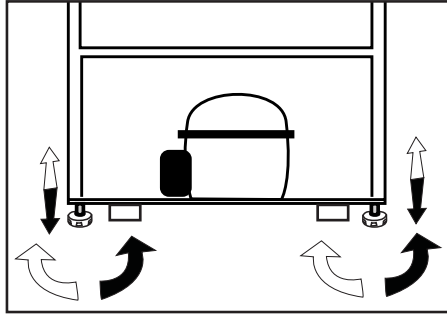

Adjusting the legs (*optional)

If your refrigerator is unbalanced:

You can balance your refrigerator by turning the legs of it as illustrated in the figure. The corner where the leg exists is lowered when you turn in the direction of black arrow and raised when you turn in the opposite direction. Taking help from someone to slightly lift the refrigerator will facilitate this process.

* Jgu f tvclf duqbsut bsf opujodwef e jo ü f qspveduzpv i bwf qvdsi bt f e, ü f o jujt wbrje gspü f s n pef rtr/

Füße einstellen (*optional)

Wenn Ihr Kühlschrank nicht absolut gerade steht:

Sie können den Kühlschrank – wie in der Abbildung gezeigt – durch Drehen der FüÙe ausbalancieren. Wenn Sie in Richtung des schwarzen Pfeils drehen, senkt sich die Ecke, an der sich der Fuß befindet. Beim Drehen in Gegenrichtung wird die Ecke angehoben. Diese Arbeit fällt erheblich leichter, wenn ein Helfer das Gerät etwas anhebt.

* Falls Teile nicht zum Lieferumfang des erworbenen Produktes zählen, gelten sie für andere Modelle.

Ajustarea picioarelor (*opțional)

Dacă frigiderul este neechilibrat:

Puteți echilibra frigiderul prin rotirea picioarelor sale așa cum este reprezentat în schiță.

Colțul unde există piciorul se coboară atunci când rotiți în direcția săgeții negre și se ridică atunci când rotiți în direcția opusă. Acest procedeu va fi mai ușor dacă cineva vă ajută să ridicați ușor frigiderul.

* În cazul în care unele componente nu sunt incluse în produsul pe care l-ați achiziționat, atunci sunt valabile pentru alte modele.

Réglage des pieds (*en option)

Si votre réfrigérateur est déséquilibré:

Vous pouvez l'équilibrer en tournant les pieds de celui-ci comme illustré sur le dessin ci-dessus. Pour abaisser le produit, veuillez tourner les pieds dans le sens inverse des aiguilles d'une montre (flèches noires). Pour monter le produit, veuillez tourner dans le sens contraire (flèches blanches). Lever légèrement l'avant du produit, avec l'aide d'une personne tierce, vous facilitera le processus.

* Si les pièces concernées ne sont pas incluses dans le produit que vous avez acheté, elles sont valables pour d'autres modèles.

Regolazione dei piedini (*opzionale)

Se il frigorifero non è in equilibrio:

È possibile bilanciare il frigorifero ruotando i piedini come illustrato in figura. L'angolo in cui i piedini sono più bassi quando girati in direzione della freccia nera e rialzati quando girati in direzione opposta. Un aiuto per sollevare leggermente il frigorifero faciliterà tale processo.

* Se le parti in oggetto non sono incluse nell'apparecchio acquistato, significa che sono da intendersi per altri modelli.

Ayakların Ayarlanması (*opsiyonel)

Buzdolabınız dengesiz duruyor ise:

Buzdolabınızın ayaklarını şekildaki gibi döndürerek dengeli durmasını sağlayabilirsiniz. Siyah ok yönüne döndürüldüğünde ayağın bulunduğu köşe alçalır, diğer yöne döndürüldüğünde ise yükselir. Bu işlem yapılırken birinden dolabı hafifçe kaldırması için yardım almanız kolaylık sağlayacaktır.

* Satın almış olduğunuz üründe ilgili parçalar yoksa başka modeller için geçerlidir.

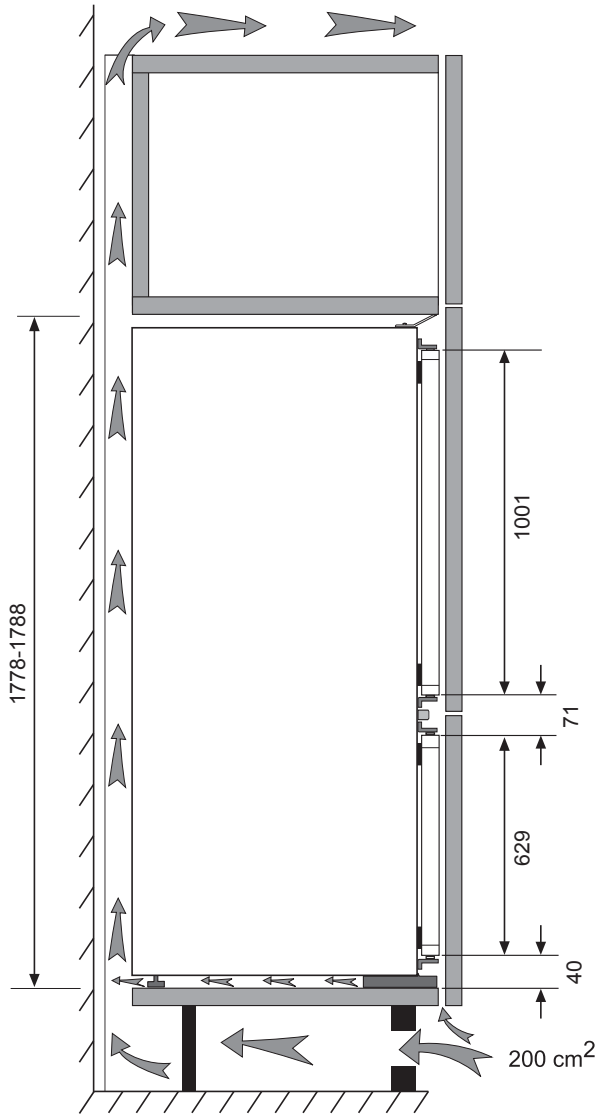
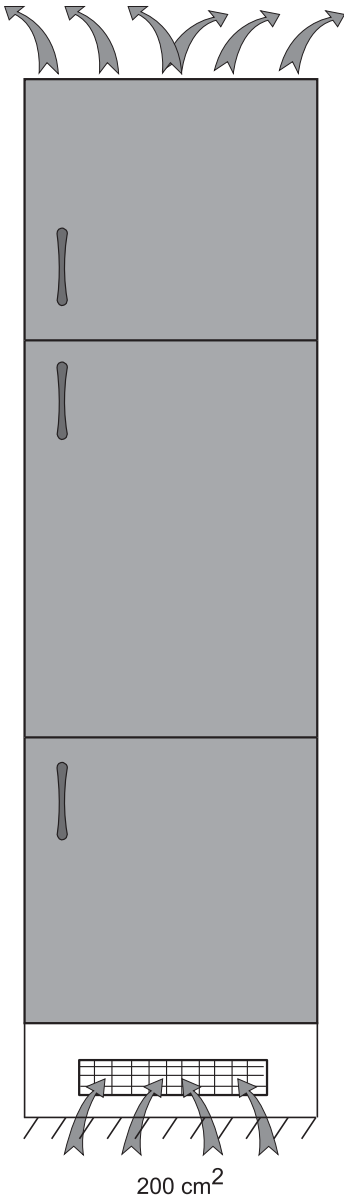

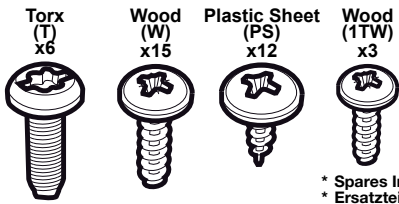

- * Spares Included
- * Ersatzteile inklusive
- * Pièces incluse
- * Pièces incluses
- * Ricambi inclusi
- * Dahil olan parçalar

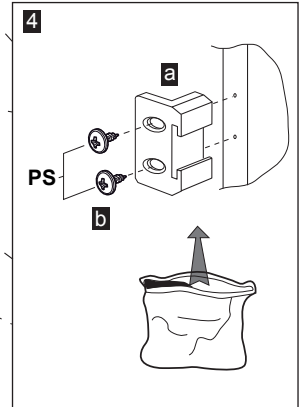
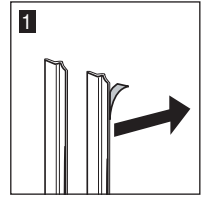
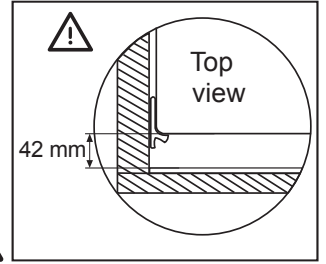
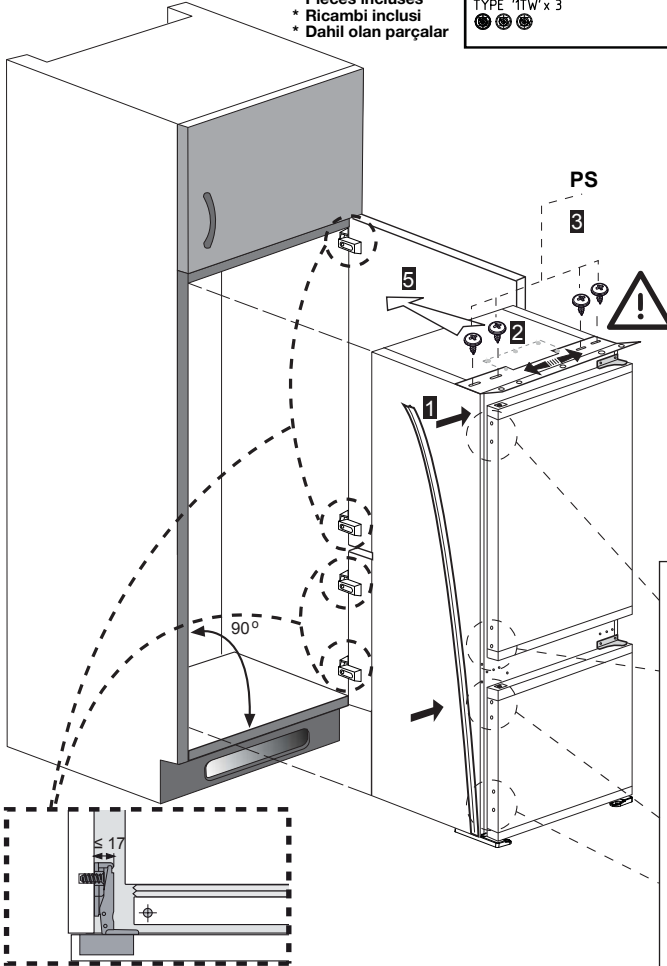
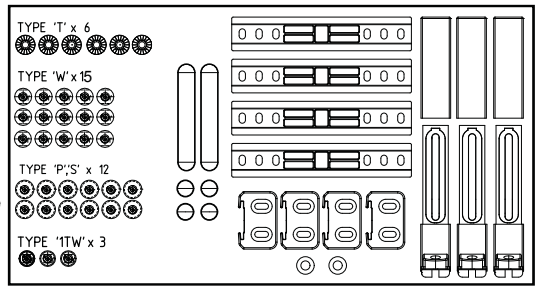

Note: Installation step for 2, screws for connecting top plastic part should not be screwed very hard, because of moving the plastic part easily left or right side.

Hinweis: Installationsschritt 2, Die Schrauben zum Fixieren des Kunststoffteils sollten nicht zu fest angezogen werden, da sich das Kunststoffteil ansonsten nach links oder rechts verschieben kann.

Notă: Instalare-pasul 2, șuruburile pentru conectarea părții superioare din plastic nu ar trebui să fie înșurubate foarte tare, pentru ca aceasta să poată fi mișcată ușor de la stânga la dreapta.

Remarque: A l'étape 2 de l'installation, les vis pour fixer l'accessoire en plastique sur la partie supérieure ne doivent pas être vissées à fond, afin d'éviter tout déplacement latéral de cette pièce pendant le vissage.

Nota: Fase di installazione per 2, viti per connettere la parte in plastica superiore non devono essere serrate, per consentire il movimento della parte in plastica a sinistra o a destra.

Not: 2 numara ile gösterilen montaj adımımda üst bağlantı plastiğini kaydırabilmek için bağlantının yapıldığı vidaları tam sıkmayınız.

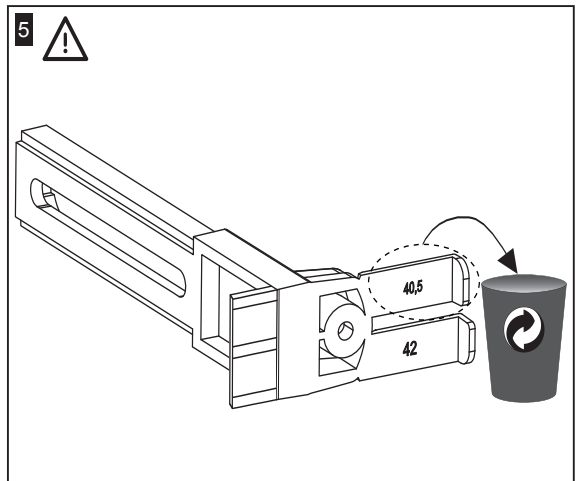
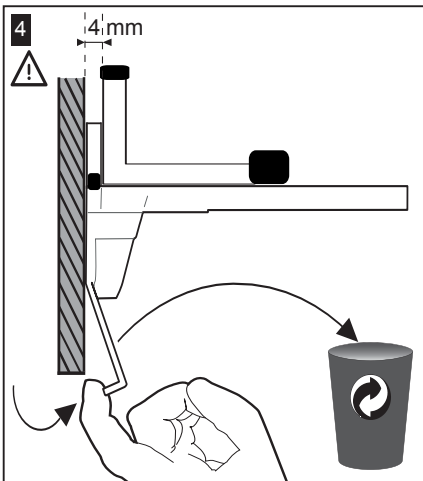
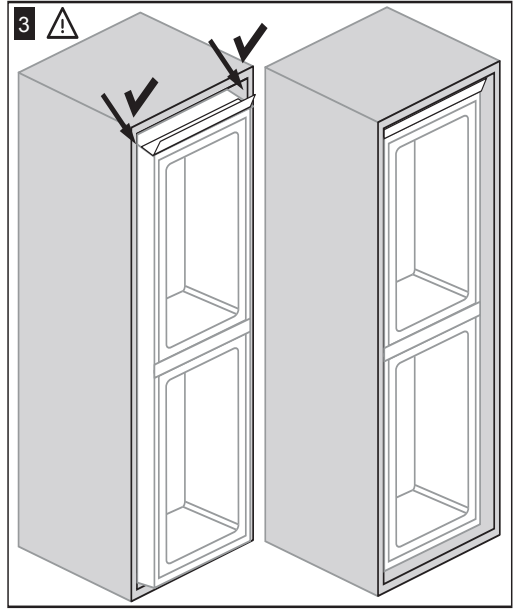
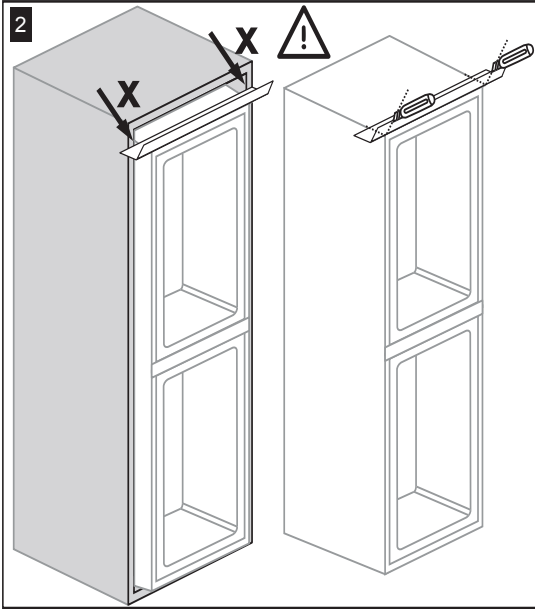
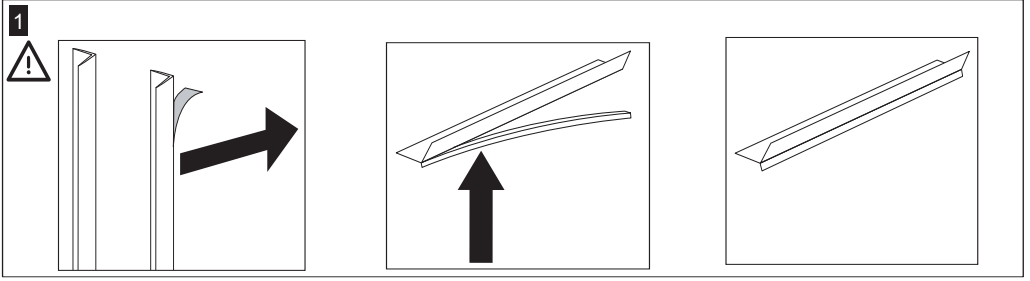

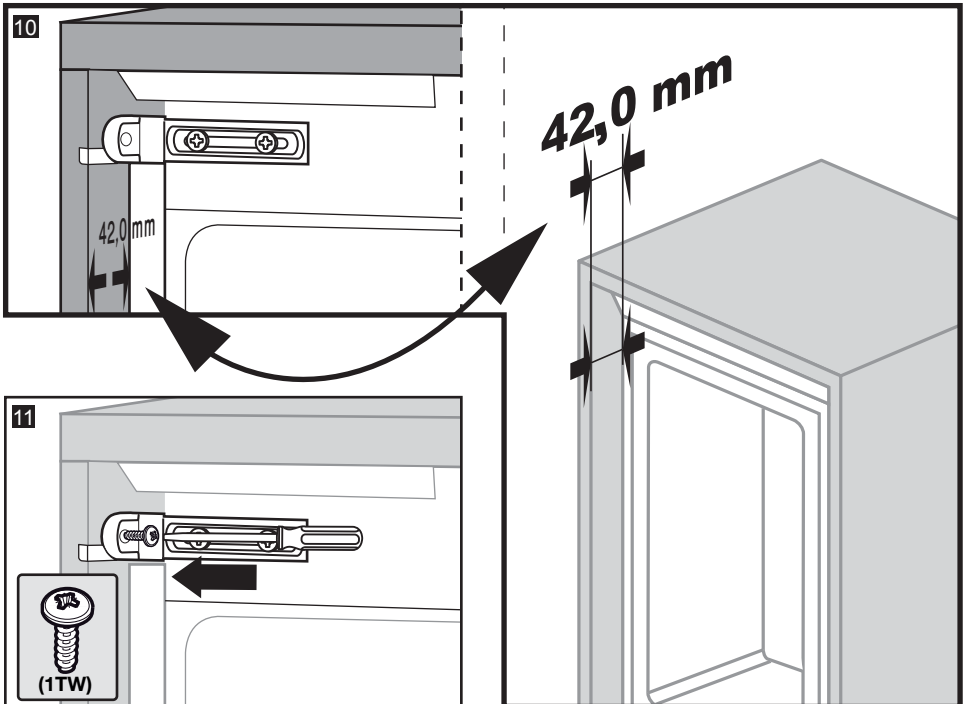
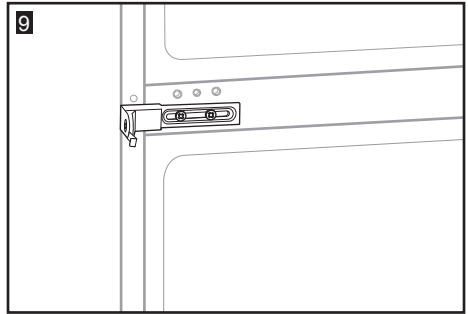
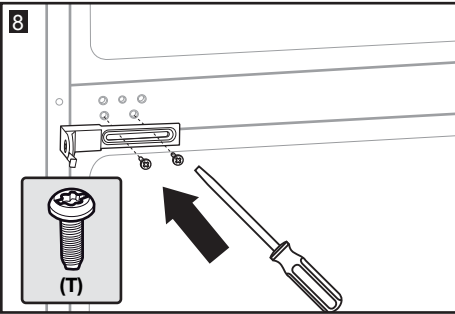
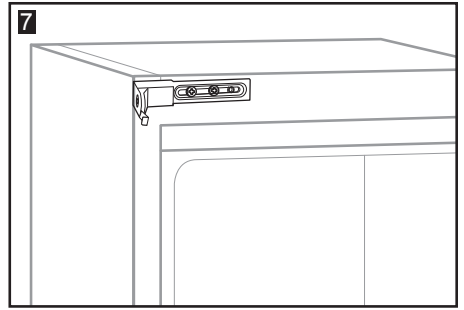
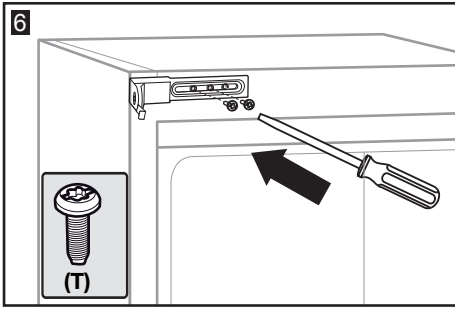

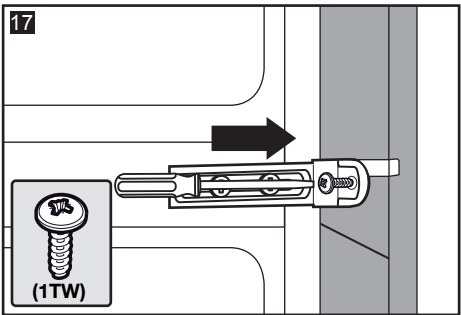
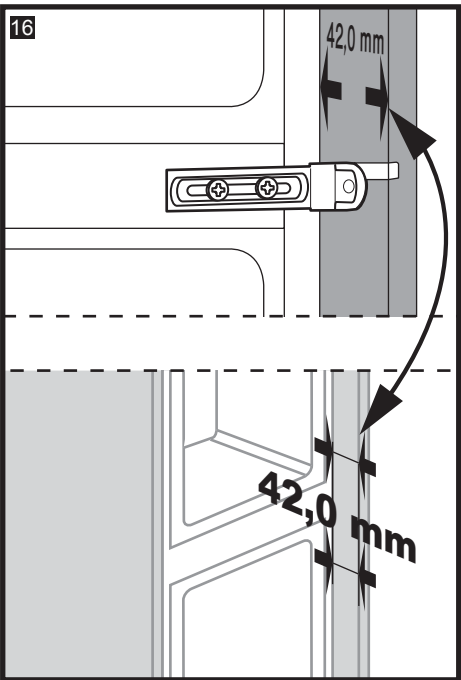
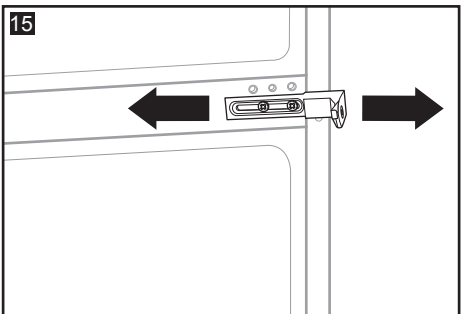
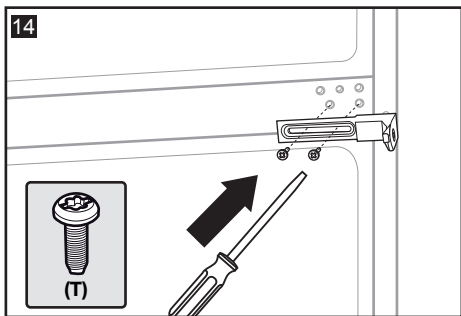
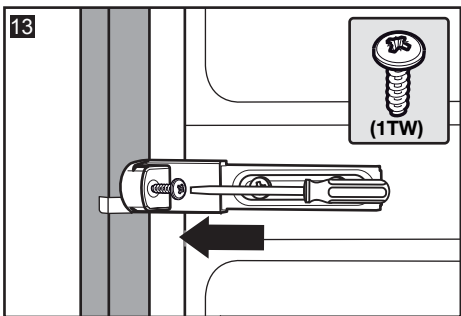
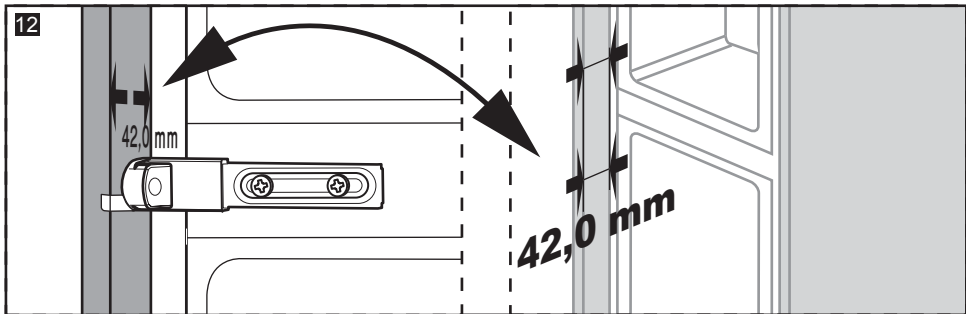

18

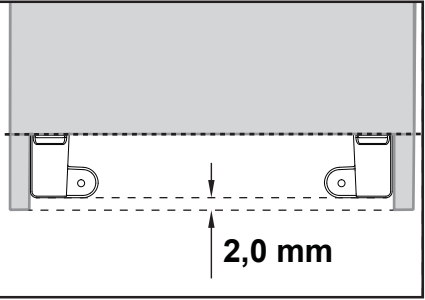
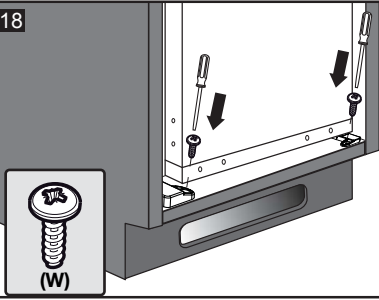

19

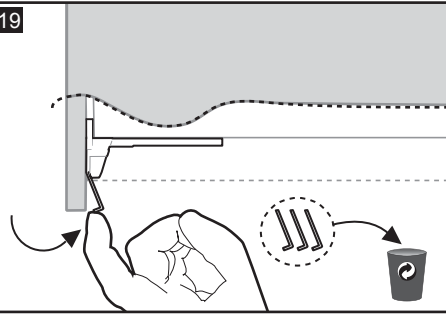

20

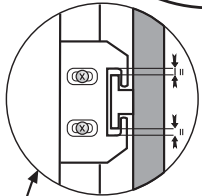
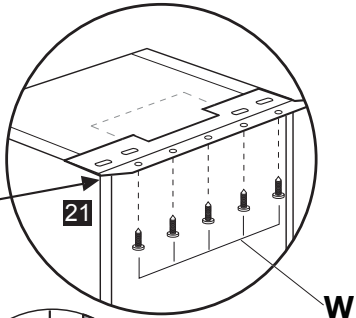
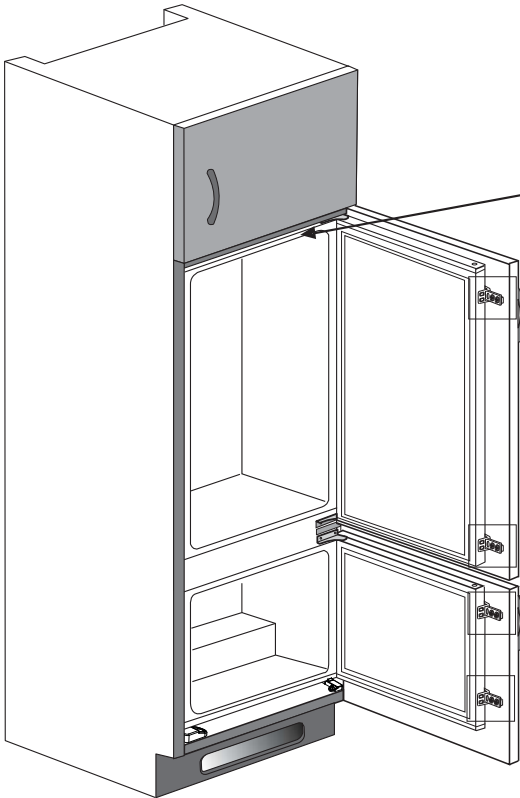
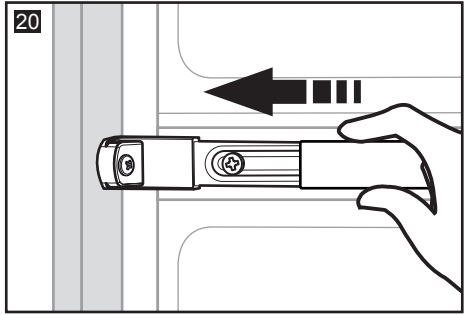

21 mm

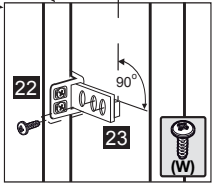



Note: Installation step for 8* and 20* - only for Italy models.

Hinweis: Installationsschritt 8* und 20* - nur für Italien Modelle.

Notă: Instalare pasul 8* și 20* - doar pentru modelele de Italia.

Remarque: A l'étape 8* et 20* de l'installation - uniquement pour les modèles italiens.

Nota: Fase di installazione per 8* e 20* - solo per i modelli italiani.

Not: 8 * ve 20 * için montaj adımı - yalnızca İtalya modelleri için.

